

F. HANSON.  
Wood Turning Machine.

No. 234,472.

Patented Nov. 16, 1880.

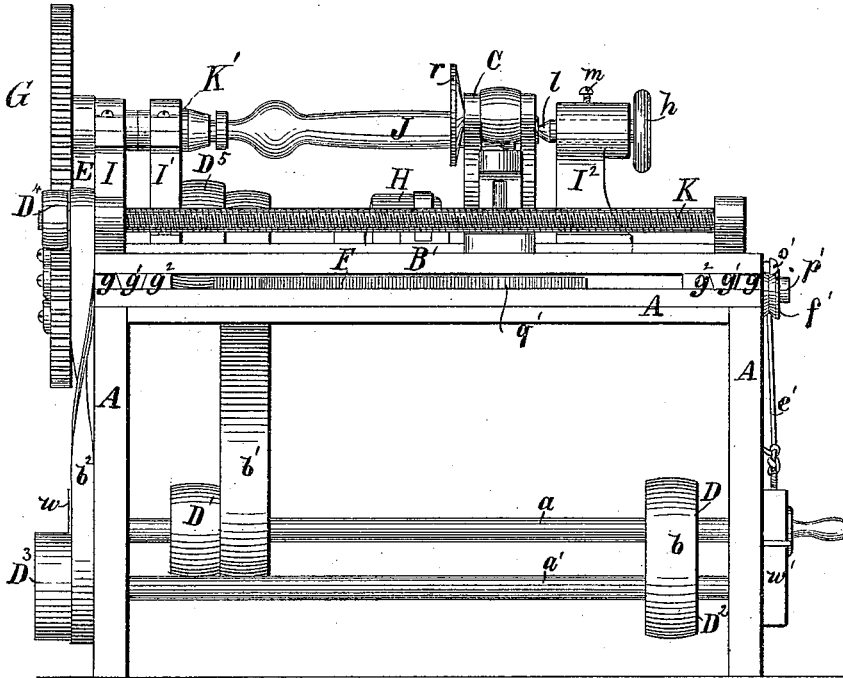

Fig. 2.

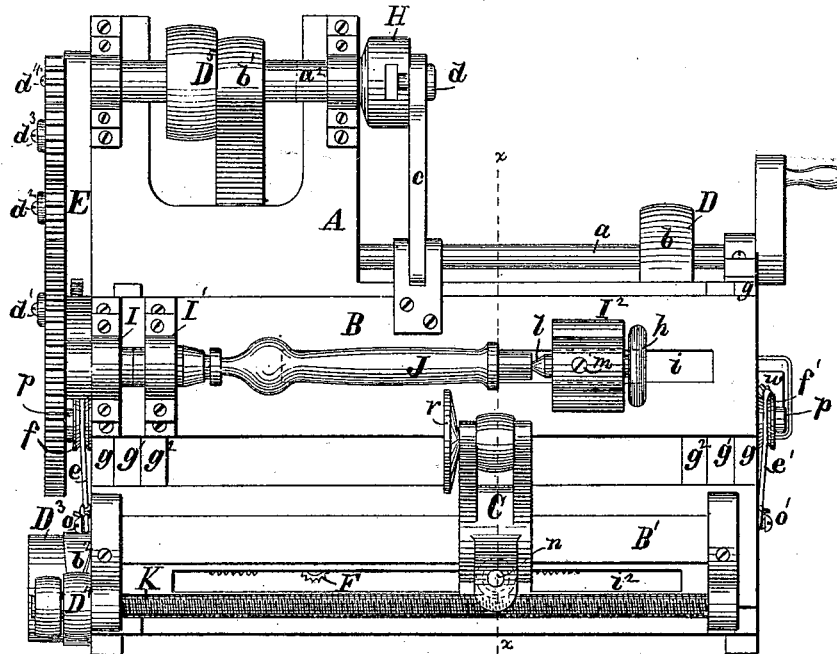

Fig. 1.

Witnesses:

*W. M. Swan*  
*H. A. Olmsted*

*Freeman Hanson* Inventor:

*W. P. Peble Jr*  
Attorney.

F. HANSON.  
Wood Turning Machine.

No. 234,472.

Patented Nov. 16, 1880.

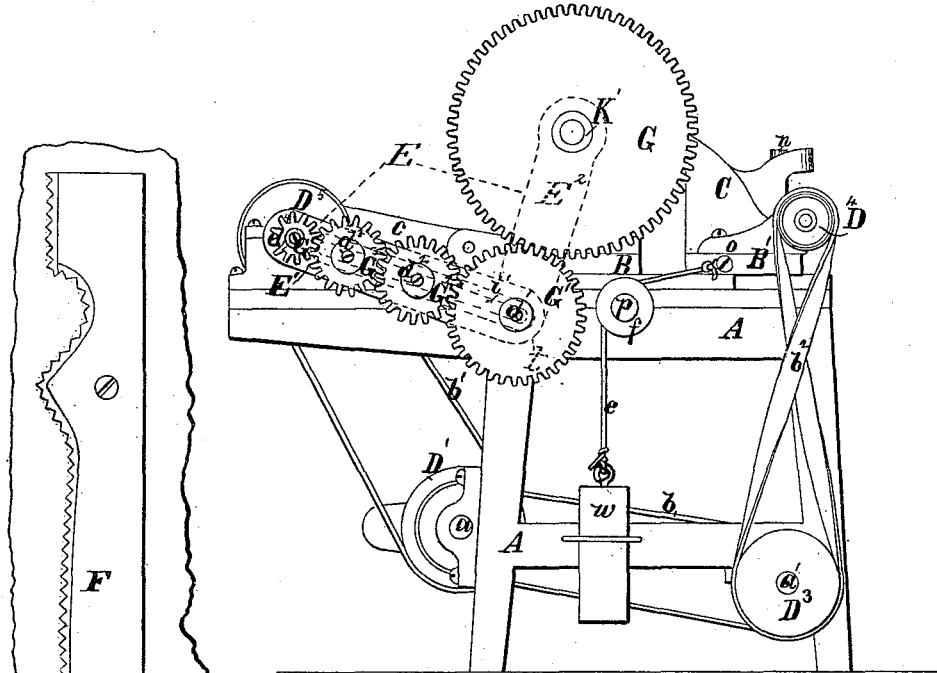

Fig. 3.

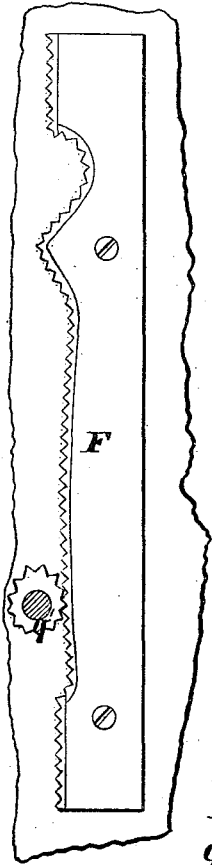

Fig. 5.

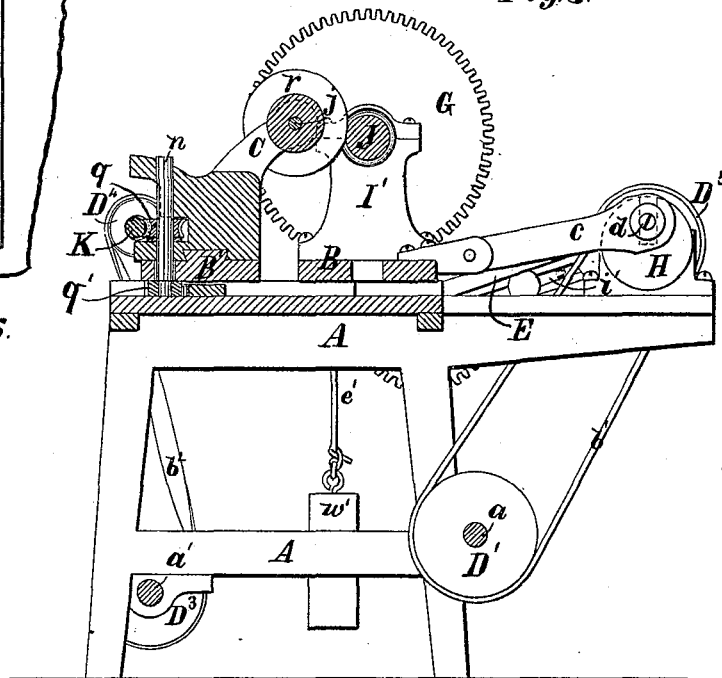

Fig. 4.

Witnesses:

*W. W. Swan*  
*H. G. Olmsted*

*Freeman Hanson* Inventor:

by *W. P. Preble Jr*  
Attorney.

# UNITED STATES PATENT OFFICE.

FREEMAN HANSON, OF HOLLIS, MAINE.

## WOOD-TURNING MACHINE.

SPECIFICATION forming part of Letters Patent No. 234,472, dated November 16, 1880.

Application filed April 10, 1880. (No Model.)

*To all whom it may concern:*

Be it known that I, FREEMAN HANSON, of Hollis, in the county of York and State of Maine, have invented a new and useful Improvement in Wood-Turning Machines, of which the following is a specification.

The object of my invention is to control the approach of the cutting-tool in a wood-turning machine toward the object to be cut at the same time that it moves along its side, by means of a stationary pattern or former with a geared edge, in such a way that the shape given to the posts, table-legs, pillars, and other objects cut by the machine corresponds with and is determined by the shape given to the former or pattern.

The mechanism by which this is done is shown in the accompanying drawings.

Figure 1 is a top plan. Fig. 2 is a front elevation. Fig. 3 is an end view, showing the gear-wheels. Fig. 4 is a transverse section at the line *x x* of Fig. 1. Fig. 5 is a detail of the pattern or former. This detail is on twice the scale of the other figures.

The same letters refer to similar parts in the different figures.

A is the frame-work which supports the moving parts of the machine. B is a sliding bed-plate, which carries the mechanism for holding and rotating the wood. B' is a sliding bed-plate, which carries the cutter-head and its operating mechanism. C is the cutter-head.

Power is applied to the machine through the shaft *a*, which turns in the frame-work. This shaft *a* carries the pulleys D and D'. D is a solid pulley, connected, by the belt *b*, with the pulley D<sup>2</sup> on a shaft, *a'*, which also turns in the frame-work, and to which it thus communicates motion. On the other end of the shaft *a'* is the pulley D<sup>3</sup>, connected, by the belt *b'*, with the fast and loose pulley D<sup>4</sup>, which operates the sliding cutter-head, as hereinafter explained.

D', before spoken of as being on the shaft *a*, is a cone-pulley, and is connected by the belt *b'* with the cone-pulley D<sup>5</sup> upon the shaft *a*<sup>2</sup>. The shaft *a*<sup>2</sup> turns in the frame-work and carries a slotted socket-head, H, on one end and the slotted link E on the other. This slotted link E consists of two parts or branches, E' and E<sup>2</sup>, pivoted together at *t*. The branch E' is slotted

longitudinally, and its free end is hung upon the shaft *a*<sup>2</sup>. The branch E<sup>2</sup> is solid, and its free end is hung upon the short shaft K', as hereinafter explained.

The slotted socket-head H is provided with a crank-rod, *c*, fastened to it by the connecting-pin *d*, which is made adjustable in the slot of the socket-head, and by its distance from the center of the head regulates the throw of the crank-rod *c*. The other end of this crank-rod *c* is connected with the bed-plate B, and gives to it a reciprocating backward and forward motion from the rotation of the shaft *a*<sup>2</sup>. This bed-plate slides upon the guides *g g* in the guide-cleats *g' g'*, and carries with it the mechanism for holding and rotating the wood, as before stated.

This mechanism consists of the fixed posts or uprights I I' at one end of the bed-plate B, and the adjustable post I<sup>2</sup> near the other end of the bed-plate. The wood to be operated upon, J, is held between the posts I' and I<sup>2</sup>, one end resting in and being turned by the short shaft K', with lathe-chuck attached, in the post I', and the other end turning on the spindle *l* in the post I<sup>2</sup>. This spindle *l* passes through the head of the post I<sup>2</sup>, and has at its other end the wheel *h*, by which it is turned into contact with the wood. The set-screw *m* holds the spindle in position and prevents it from turning with the wood.

A slot, *i*, runs lengthwise in the bed-plate B, and in this slot the post I<sup>2</sup> is made adjustable, to correspond to the different lengths of the objects desired to be shaped.

Rotation is given to the shaft K', and hence to the wood held by it, by the gear-wheel G, which is rigidly fastened to the shaft K'. The gear-wheel G derives its motion from the shaft *a*<sup>2</sup> through a system of gear-wheels, G', G<sup>2</sup>, G<sup>3</sup>, and G<sup>4</sup>, which are hung upon the slotted link E, one end of which, as before stated, is hung upon the shaft *a*<sup>2</sup>, and the other end of which is hung on the shaft K'. These gears mesh into each other and the gear G, and are kept in gear by being made adjustable in the slot *i'* of the slotted branch E'. This is done by the connecting-pins *d'*, *d*<sup>2</sup>, and *d*<sup>3</sup>. The smallest gear, G<sup>4</sup>, is fastened directly to the shaft *a*<sup>2</sup> by the connecting-pin *d*<sup>4</sup>, from which it thus derives its rotation.

Every outward motion of the crank-rod *c*

causes the bed-plate B to slide in its cleats  $g'$  away from the shaft  $a^2$ , and as the bed-plate carries the gear-wheel G and posts I, I', and I<sup>2</sup> with it, this outward motion extends the slotted link E, without interfering with the rotation of the gears. At each backward or inward motion of the bed-plate and crank-rod the train of gear-wheels is lowered by the contraction of the slotted link, and thus their rotation is not interrupted. Thus simultaneously with the sliding or transversely-reciprocating motion of the bed-plate there is a constant rotation of the wood carried by it.

Instead of a transversely-reciprocating motion the bed-plate B may be made to slide up and down, or to rock back and forth. These two motions are readily obtained, the up-and-down motion by making the guide-cleats vertical, and placing the shaft  $a^2$  and socket-head H below the bed-plate B, instead of at its side, and the rocking motion by setting the bed-plate upon rockers hung upon uprights fastened to the frame-work, instead of guides and guide-cleats.

It is obvious that if the bed-plate B were stationary the constant rotation imparted to the wood by the train of gear-wheels G, G', G<sup>2</sup>, G<sup>3</sup>, and G<sup>4</sup> would cause the surface of the wood to be shaped like a cylinder, so that a cross-section at any point would be a circle. The sliding or rocking motions of the bed-plate change this circular cross-section to an oval, a polygon, a rosette, or any other shape desired of regular or irregular outline, and with straight, curved, hollowed, or scalloped edges. Thus, if the machine is so adjusted, by arranging the speed and position of the gear-wheels with reference to the motion of the bed-plate, that the large gear, G, turns once for every two sliding or rocking motions of the bed-plate back and forth the cross-section of the wood or table-leg shaped will be an oval. If the proportion is one to three, instead of one to two, the result will be a triangle; if one to four, a square, and so on. These different proportions are obtained by the substitution of intermediate gears of a different number of teeth from G', G<sup>2</sup>, and G<sup>3</sup>.

By altering the length of slide of the bed-plate without changing its relative speed the sides of these polygonal cross-sections may be made concave, straight, or convex, as desired, and in this way, by slight changes of adjustment, a great variety of outlines may be given to posts or table-legs shaped by the machine; but having previously patented the mechanism which I use to produce these motions of the bed-plate I make no claim to them here, but refer to them to explain more fully the action of the mechanism peculiar to this machine.

The cutter-head C, as before stated, is carried on the bed-plate B', which slides by guides  $g^2$  in the guide-cleats  $g' g'$ . This bed-plate is drawn toward the bed-plate B by a constant force, which consists of the weights  $w w'$ , connected to the bed-plate B' at  $o o'$  by cords  $e e'$  passing over the pulleys  $f f'$  hung on the frame-

work at  $p p'$ . This constantly-drawing force may be obtained in many ways, but I prefer the use of weights and pulleys as most convenient. The action of this constantly-drawing force is resisted by the former F, as hereinafter explained.

The bed-plate B' has a worm-screw, K, which runs nearly its whole length, and is turned by the fast and loose pulley D<sup>4</sup>. It also has a slot,  $i^2$ , which runs longitudinally under the screw K, and in this slot the cutter-head is moved back and forth by the action of the screw K upon a wheel,  $q$ , in the cutter-head.

The cutter-head C carries a rotating arbor,  $j$ , which has a disk,  $r$ , on its outer end, in which the cutting-tool is inserted. The object of this disk is to give the cutting-tool a larger sweep than it could have if inserted in the edge of the arbor. The cutter-head C is also provided with a vertical shaft,  $n$ , on which are two gear-wheels,  $q$  and  $q'$ , one above the bed-plate B' and the other below. This shaft is turned and the cutter-head fed along in the slot  $i^2$  by the engagement of the teeth of the wheel  $q$  by the worm-screw K. The teeth of the gear-wheel  $q'$  mesh into the teeth of the former F, which extends nearly the length of the slot  $i^2$  under the bed-plate B' and parallel to it, and against which the wheel  $q'$  is held by the weights  $w w'$ , as before explained. This former F is geared with teeth to correspond to those of the wheel  $q'$ , and is fastened rigidly to the frame-work A. Thus, by its resistance to the action of the weights  $w w'$ , the former F controls the motion of the gear-wheel  $q'$  and allows only one tooth to pass at a time, as the wheel  $q'$  is turned in unison with the shaft  $n$  and wheel  $q$ , by the screw K. The character of this former is shown in Fig. 5; but my invention is by no means limited to the exact shape there shown. On the contrary, the object of my invention is to use a great variety of these shapes, so that long objects of very different shapes may be turned from these patterns or formers by the automatic action of the machine. The rule of construction of these formers is to make them as nearly as possible the shape of one half the linear section of the object to be shaped.

If it is desired to have part of the wood to be operated upon retain its original shape, it may be accomplished by making the former hold the gear-wheel  $q'$ , while passing that place, so far from the wood that the chisel cannot act upon it.

The only limit put upon the shape which can be given to this former lies in the fact that any depression made in it must be large enough to allow the gear-wheel  $q'$  to enter and leave it without ceasing to turn on its axis.

An important feature of this former is that it is provided with teeth into which the teeth of the gear-wheel  $q'$  mesh. This secures a uniform motion of the cutter-head on its path, and without such a device there would be nothing to prevent the wheel from being drawn suddenly to the bottom of a depression in the

former, which would tear the wood and probably break the cutting-tool. If, however, the shape of the former is without any sharp depressions, it need not be geared, and an ordinary friction-wheel may be used instead of the gear-wheel  $q'$ .

The gear-wheel  $q'$ , though circular in the drawings, may be oval, hexagonal, octagonal, or of any other shape made up of curves or straight lines without re-entrant angles. The effect of this would be to allow pillars of a great variety of shapes to be cut from the same pattern.

It is obvious that when the wheel  $q'$  engages the teeth of the former F by the teeth upon its longer diameters, as in ovals, hexagons, or octagons, the cutting-tool is held farther from the wood, and when by the teeth upon its shorter diameter, the cutting-tool would be nearer the wood than when a circular wheel is used. This makes the depressions and elevations cut upon the pillar more marked if the longer diameters act upon the elevations and the shorter upon the depressions, and makes them less marked if vice versa.

As the shape of the linear section of the pillar cut depends wholly upon the progress of the gear-wheel  $q'$  along the former F, any change made in the wheel  $q'$  or in the former F will produce a corresponding change in the shape given to the wood.

The automatic operation of the machine is exceedingly simple. The log from which the post or other object is to be turned is held by the spindle  $l$  and collar  $K'$  and rotated by the gear-wheels  $G$   $G'$   $G^2$   $G^3$   $G^4$ . The cutter-head is started at the end of the former F nearest the post  $I^2$ , and is made to follow the path of

the former F by the rotation of the worm-screw K. The cutting-tool upon the arbor  $j$  constantly describes a circle round the disk  $r$ . The paths of this cutting-tool and the rotating wood are brought into and out of contact at the proper intervals, either by the motions of the bed-plate B or of the gear-wheel  $q'$ , as the case may be. When the cutter-head has traveled the whole length of the former F the post, now shaped, is removed and a new log inserted between the uprights  $I'$  and  $I^2$ . The cutter-head is slipped back to its starting-point by drawing the bed-plate B' away from the former, and the cutting of the second post begins.

I claim—

1. In a wood-turning machine, a stationary geared pattern or former, F, for controlling the approach of the cutter-head to the wood to be cut while the cutter-head is moved along said former by the action of gear-wheels and a worm-screw, K, substantially as shown and described.

2. A wood-turning machine provided with a stationary geared former, F, and a wheel,  $q'$ , of oval or polygonal shape, which engages the teeth of said former F, and thus controls the motion of a sliding bed, B', which carries the cutter-head, substantially as hereinbefore described.

3. The combination of a stationary former, F, and a cutter-head, C, moving by the action of gear-wheels  $q$  and  $q'$  upon said former, with a worm-screw, K, to impart motion to said wheels, substantially as hereinbefore described.

FREEMAN HANSON.

Witnesses:

GEORGE E. BIRD,  
W. W. THOMAS, Jr.